

# Design, fabrication and construction of Railway Bridge over Södertälje canal

Michael B. Thulstrup<sup>1</sup>, Mattias Nilsson<sup>2</sup>, Robert Hällmark<sup>3</sup> & Jens P. Nielsen<sup>4</sup>

<sup>1</sup>*Project Manager, MT Højgaard a/s, Denmark*

<sup>2</sup>*Design Engineer, Rambøll Sweden, Luleå, Sweden*

<sup>3</sup>*Design Engineer, Rambøll Sweden, Luleå, Sweden*

<sup>4</sup>*Project Manager, Promecon a/s, Denmark*

**ABSTRACT:** The new railway bridge project over Södertälje Canal comprises the replacing of the 80 year old and much worn out bridge. The new bridge consist of a main lifting bridge section spanning 56 m over the canal and two 70 m approaching bridges on each side of the main bridge. The total bridge length is 229.5 m. The main lifting bridge is a steel truss bridge structure and capable of opening when large ships pass under. Normal elevation free height is 26.7 m and the top elevation is app. 40.5 m. The approach bridges consist of a composite bridge with a main steel box girder and an in-situ cast concrete top plate.

## 1 GENERAL DESCRIPTION OF THE BRIDGE

### 1.1 *Project*

In general not many lift bridges have been built in Scandinavia, but during the recent years there are two examples of bridges of this kind. One of these two bridges is presently under construction in Södertälje, Sweden (20 km south of the capital Stockholm). This bridge is significant since it is built as a high bridge with a clearance of 26.7 m and with a lifting capacity of 14.6 m, and as such the Södertälje Bridge is different from other similar types of bridges.

The existing railway bridge, which is almost 80 years old, is in a very bad condition and therefore has a limited remaining life length. The old bridge is frequently under repair, and crossing trains run at highly reduced speed. Due to the bad condition of the bridge lifting of the existing bridge must take place with extra time for operation, and there are often technical problems. This is a nuisance to both train and canal traffic. The bridge was not built for present criteria for heavy train and canal traffic and in addition the surrounding residential neighbourhood is exposed to heavy traffic noise.

The new Södertälje railway bridge is located between the old bridge and the E4 double highway bridge and the Saltsjö bridge, all of these bridges going across the heavily trafficked Södertälje canal. This area is both a busy residential and industrial area. Almost 250 trains, mainly commuter trains to and from Stockholm, cross the exiting bridge every day, and many commercial ships as well as private leisure boats go through the canal every day. All this traffic still takes place during the construction period. See figure below for arial photo of the construction site.



Figure 1. Aerial photo of construction site taken during mobilization.

During the construction of the new railway lift bridge the actual construction site has only 50 metres width, situated between two other bridges, and the existing fragile railway bridge in operation is a bare 5 metres from the new railway bridge. The slopes of the canal are up to 30% and very unstable. These conditions mean that for the installation work must be used conventional erection techniques such as launching and wire lifting devices. Also, part of the installation is being done using large mobile cranes.

## 1.2 Contract and Client

MT Højgaard signed the design and build contract with the Swedish Banverket in March 2006 after an international tender competition. The contract documents consisted of technical specifications with functionality criteria that had to be implemented in the detailed design of the bridge. During the tender phase Rambøll Denmark (consulting engineering company) assisted with the tender design and was after the award of the contract also involved in the detailed design. The main design was managed by Rambøll Denmark, whilst other branches of Rambøll were involved in designing steel pile, steel bridge, and machinery. The main steel bridge structures were designed by Rambøll Luleå.

The project is divided in two parts. One part comprises construction of the bridge with approaching bridges, machinery, railway embankment and railway accessories ready for working performance – as such inclusive of all equipment necessary for a train to cross the bridge – and with the bridge fully in operation by summer 2010. The second part comprises demolition of the old railway bridge, restoration of the slopes etc.

## 2 PROJECT DESCRIPTION

### 2.1 Overall description of the project

The main bridge span, the lifting part, crosses the canal with a free length of 57 m, and lift part can be lifted 14.6 metres above normal elevation of 26.7 m, when large and tall ships go through the canal. Bridge opening takes place a couple of times every day. The lifting bridge has two approach bridges, each consisting of two parallel bridges. Total length of approach bridges and lifting bridge is 229.5 m.

The bridges have two abutments structures (line 1 and 6), two intermediate piers (line 2 and 5) and two pylons structures (line 3 and 4). Each pylon structure consists of two parallel pylons with a crossbeam below railway elevation. See figure below for longitudinal and cross sections.

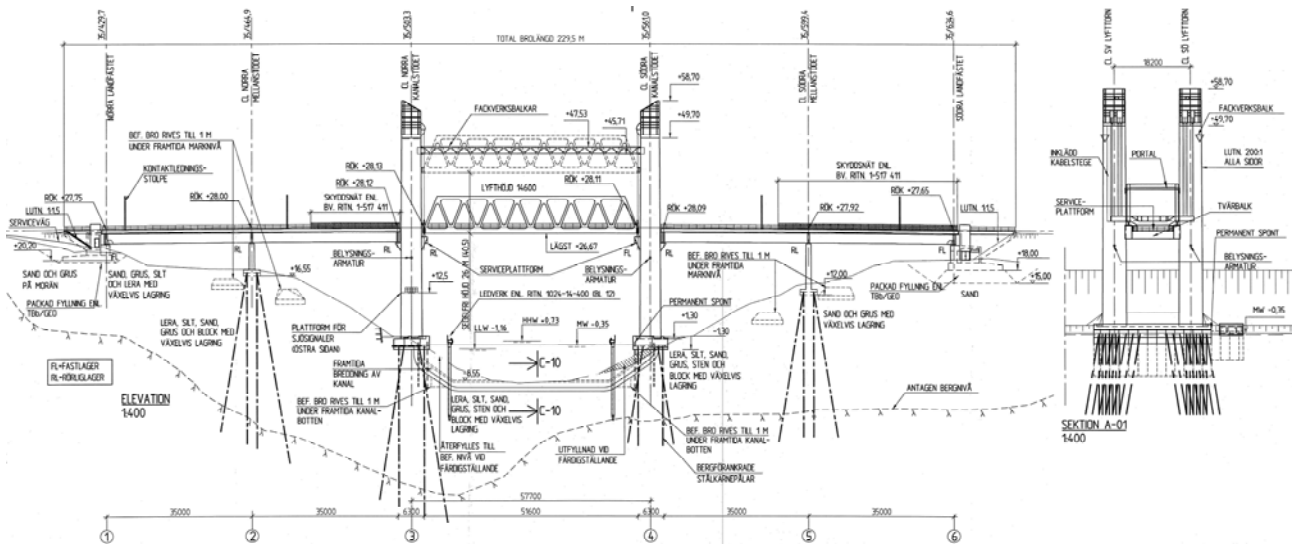

Figure 2. Longitudinal and cross section of new railway bridge

The pylon, the intermediate pier, and the north abutment structures are founded on steel core piles. The south abutment structure at line 6 is founded as a deep direct plate foundation. To lift the bridge the pylons are furnished with four lift winches complete with individual lifting machinery.



Figure 3. 3D drawing of lifting- and approach bridges

The total steel quantity used for the construction of the bridges is over 6,000 tons, whereas only 1,000 tons are used for the main bridge sections.

Table 1. Steel quantity in the bridge project

Structure	Tons
Steel piles, total 6,850 m	1,300
Reinforcement	1,250
Sheet pile walls, temporary and permanent	1,000
Lifting bridge	420
Machinery, consoles, counter weights and wire	1,400
Approach bridges	540
Temporary steel structures for installation of lifting and approach bridges	150
<b>Total steel</b>	<b>6,060</b>

### 3 DESIGN AND CONSTRUCTION METHODS

#### 3.1 *Foundation of the bridge*

The existing and the new railway bridge crosses the Södertälje canal in a geological melt water area with an original ground elevation at +15 m above the canal water level. The present canals have been excavated during the 1820'ies and have been extended ever since. Today the depths of the canal are app. -9.0 m. The bedrock varies from -14 m at the south side to -40 m on the north side and with overbounded moraine deposits.

The soil of the slopes on each side of the existing railway bridge is very unstable and the safety against failure will increase with the new railway bridge. The abutment structures and the intermediate pier structures will be moved further up the slope and back from the crown of the slope.

The north abutment structures, line 1, and all intermediate piers and pylon structures are founded on bored steel piles installed into the bedrock. The piles are steel core piles consisting of a 219.1 mm x 6.3 mm casing which is bored between 0.5 and 1.5 m into sound bedrock. Inside the casing an Ø 150 mm solid steel rod is installed, steel grade S355 and the spacing between the rod and the casing is filled with cement grouting. The tension piles have been underbored up to 7 m into the bedrock depending of the tension force. The compression piles are placed directly on the bedrock inside the casing. The pile dimensions have been based on an optimal relation between numbers of piles, design of each pile group, economy and construction methods suitable for the present geotechnical conditions. Furthermore, this solution gives a possibility for extra piles in each group should some of the piles fail during installation or during the testing procedure after installation.

Each pile group consists of between 28 and 64 piles, and the length varies from 20 m and up to 45 m. A total of more than 6.8 km of steel piles are to be installed. See figure below for illustration of the pile groups of the different structures.

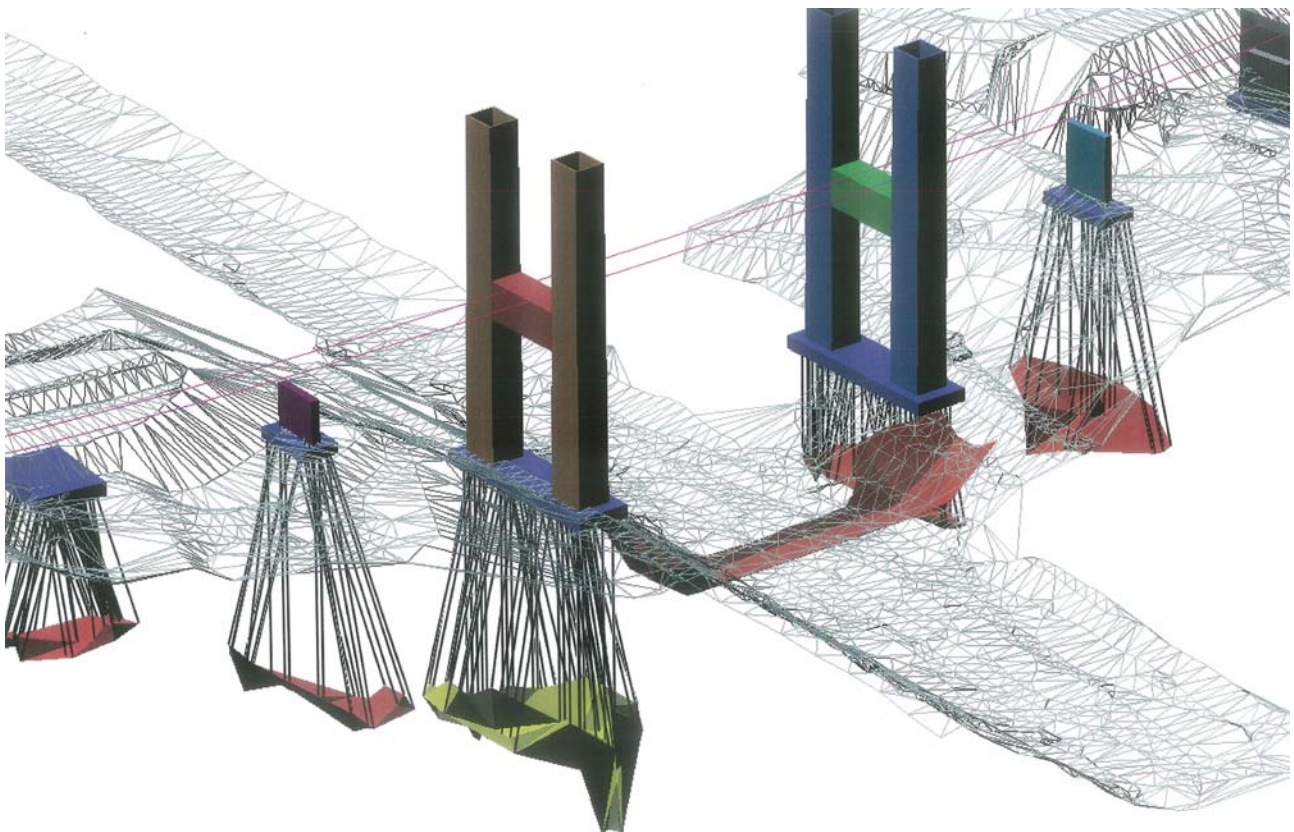

Figure 4. 3D Illustration of pile foundations and concrete structures for the abutment, intermediate piers and pylon structures

### 3.2 Concrete structures

In accordance with the specifications most of the visible concrete faces are to be cast with red coloured concrete with a synthetic ironoxide pigment added to the concrete during the mixing process. An extensive testing program, involving mock-up, test pours, colour test and testing with curing agents have been carried out before the first pour with the “red” concrete took place. Special attention was given to the investigation of “chalk sediment” problems to the concrete surface, because of the exposure to the red concrete. See figure below for photo of pylon structures after the 4<sup>th</sup> and 5<sup>th</sup> lift on the south side of the canal. Behind the pylons the intermediate pier and the abutment structure are visible.



Figure 5. Structures with red concrete

The inside dimension of the square pylons is 4.0 x 4.6 m and the wall thickness varies from 550 mm to 300 mm at the top. The height of the pylon is 50 m and the pylons have been cast in 11 pours, each of a height of approx. 4.5 m. A climbing form system is used. A cross beam between the two pylons is situated at elevation +20 m below the rail level. The concrete structures are reinforced concrete with type B500B reinforcement. The concrete is type C35/45.

### 3.3 Approaching Bridges

#### 3.3.1 Design

The approaching bridges consist of four separate box steel girders, with interacting concrete decks. Typical dimensions of the girders according to the figure below. Each of the four bridges consists of three assembly units, welded together on the construction site. The spans of the bridges are approximately 35 + 35 m.

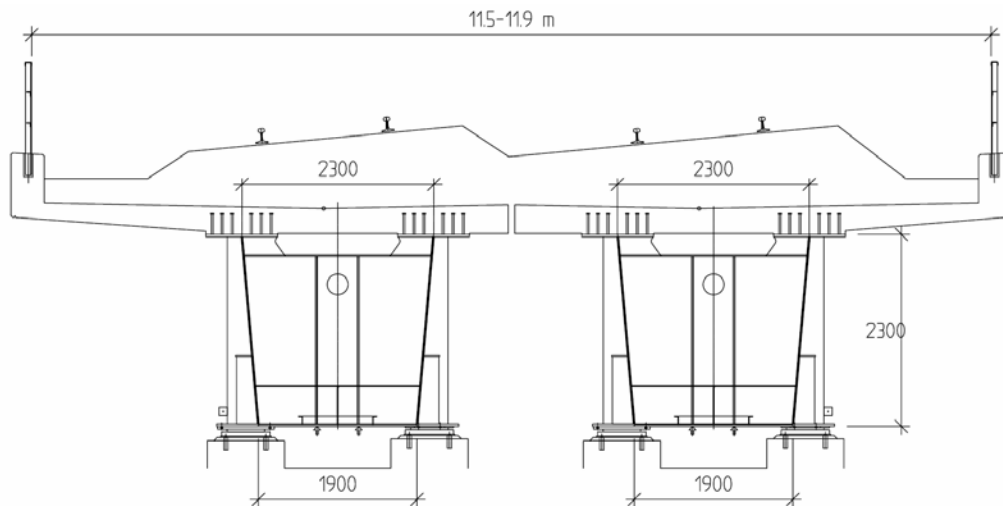

Figure 6: Typical dimensions of the girders in the approaching bridges.

The bridges are situated in so called transition curves (clothoides) with the radius varying from around R320 m, near the abutments on land, to approximately infinity when reaching the lifting bridge and its pylons. To reduce the effect of eccentricity, caused mainly by the centrifugal force due to curvature, the locations of the girders are displaced in relation to the ideal line as follows:

- Support 1: 170 mm Abutment on land, north bridges
- Support 2: 65 mm Middle support, north bridges
- Support 3: 45 mm The north pylon
- Support 4: 80 mm The south pylon
- Support 5: 120 mm Middle support, south bridges
- Support 6: 270 mm Abutment on land, south bridges

The displacements of the girders are larger on the south side of the lifting bridge than the corresponding on the north side, to ensure a future possibility to move the track a distance of 500 mm. Despite this, the effect of the curvature is significant. Together with a relatively large shear area and a moderate stiffness of the girders, the number of shear connectors is relatively large, in average around 30 studs/m.

The girders are made as so called “hybrid-girders” i.e. different material (yield strength) in the flanges and the webs. The girder webs and lower flange is made from S355 whereas the upper flange is partially S420. The bridges are dimensioned according to the Swedish code for railway bridges - BV BRO 7. The number of governing fatigue cycles for the main girders is  $2 \cdot 10^6$  and  $10 \cdot 10^6$  cycles for the cross girders. Typical critical details governed by fatigue for this kind of bridges are:

- Shear connectors on the upper flange, allowable stress range 69 MPa
- Connection of the web stiffeners to the lower flanges, allowable stress range also 69 MPa

To that, the steel girders are also dimensioned in the Ultimate limit state, to carry all loads without taking any composite benefits into accounts. The ULS is thus only governing for the upper flanges in the midspans, and the web and the lower flange near the mid-support.

### 3.3.2 Fabrication and installation

This Design of the approach bridges is a well known method in Swedish design. These four bridges have been fabricated in Finland in three sections each with an approximate length of  $2 \times 28.5$  m and  $1 \times 18$  m. When the sections are joined each bridge length is approx. 75 m.

One of the challenges to these bridges was mainly the logistics and the installation, due to both the limited space and the limited access conditions.

Figure 6 shows the arrival of one the trucks to the construction site and shows how the bridges were lifted unto a skidding track placed on top of the railway embankment and then moved into launching position on top of the abutment structure. These tracks later serve as the skidding track when the bridges, after having been welded and fitted with formwork, are launched out over the abutment structures and the intermediate column to the pylons.



Figure 7. The arrival of the steel girders from Finland and the lifting operation from truck to launching track behind the abutment structure.

### 3.4 *Lifting bridge and machinery*

#### 3.4.1 *Lifting Bridge design*

The lifting bridge is a truss girder bridge, with a length of 51.6 m and a width of 12.3 m. The bridge is entirely made of steel and will have a weight of about 420 tons.

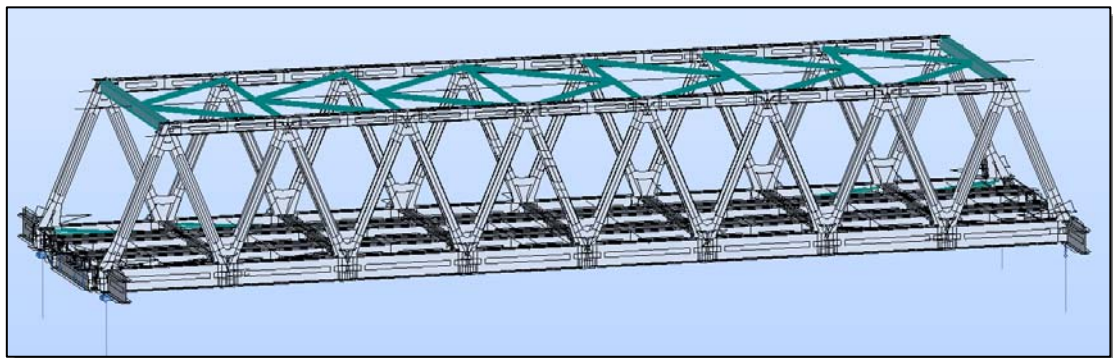

Figure 8: FEM-model, in Robot, of the lifting bridge.

#### 3.4.2 *The structure*

The bridge consists of two main truss girders that will carry the load to the main bearings at the pylon cross-beams. The bottom cord is an open box-girder (0.6x1.2 m) with one flange at the top and two flanges at the bottom. The lower flanges inwards the centre of the bridge is designed to act as rails to a mobile inspection platform. An open box-girder is also used as top chord (0.7x0.6m). The diagonals are made of welded H-sections, and are integrated in the upper- and lower box girders by large connections plates. These plates have been made larger on the side inwards the bridge. This is done in order to take care of large accidental forces, which is described more in detail later.

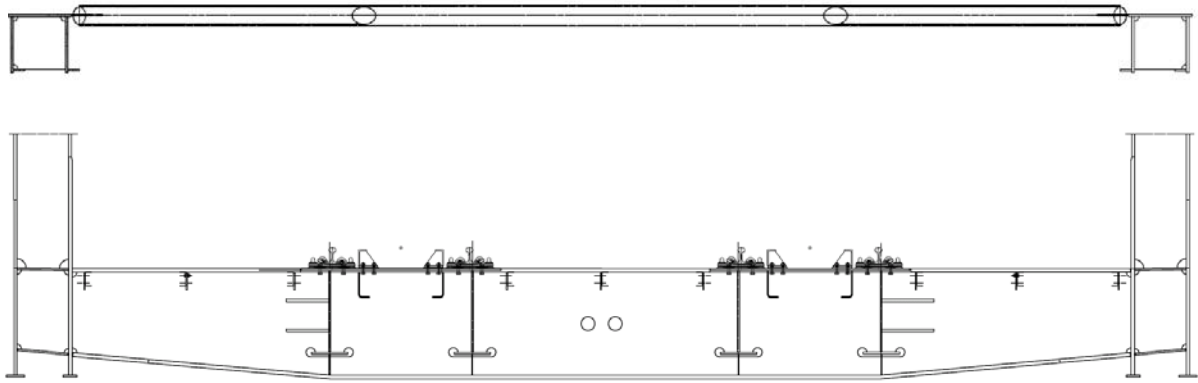

Figure 9: Cross-section showing the shape of some of the girders.

In the top of the bridge, a horizontal truss made of circular hollow profiles (219.1x6.3 and 193.7x6.3) is used to stabilise the main girders in the transversal direction. This truss is mainly designed by the bracing forces from the main girder, but it will also transfer wind loads and other transversal loads between the main trusses.

In the bottom of the bridge, cross beams are connecting the two main girders to each other. The cross beams are made of large welded I-beams, with an upper flange that are integrated into the upper flanges of the two secondary rail girders. These two rail girders will be the structural parts that are exposed to the worst fatigue, since the rail is bolted into the upper flanges by a pandrol rail fastening system. To reduce eccentric load from the trains, the rail girders follows the curve radius of the track, which is about 2000 m.

### 3.4.3 Interesting load cases

Since it is a railway bridge, fatigue is governing the design of almost every part of the lifting bridge. Like the approaching bridges, the number of governing fatigue cycles is  $2 \cdot 10^6$  for the main truss girders and  $10 \cdot 10^6$  cycles for the cross girders and rail girders.

The lifting bridge is supported by six bearings at each side of the bridge, two main bearings under the end of the truss girders, and four smaller bearings under the rail girders. This gives a rather complex support condition. There is a requirement of supporting forces of at least 20 kN at each main bearing, and 10 kN at the rail bearings. If the bridge is designed with continuous rail girders, that cantilevers the last 7 m to the rail bearings, negative forces will occur at the rail bearings. To keep a positive force of at least 10 kN, it is possible to use a negative pre-cambering of the continuous rail-girders. However, this would result in lower forces on main bearings, in the normal load cases. As a consequence of this, the primary counter weight would be lower, and the lifting machinery has to be made stronger. To avoid this, a hinge is used in the rail girders, which means that the last 7 m will be a simply supported girder, with half of its dead load acting on the bearings.

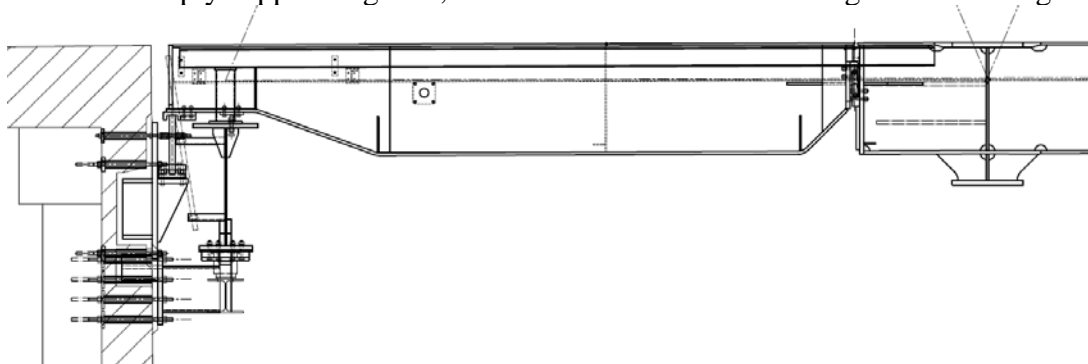

Figure 10: Illustration of the hinge in the end part of the rail beams.

The accidental loads are quite high in this type of constructions, since the diagonal in the truss girders shall be treated as columns in a bridge. This means that they have to be designed to resist an accidental force of 4 MN in the longitudinal direction of the bridge, or 2 MN in the transversal direction of the bridge. The forces shall be assumed to act 1.0 m above the top of the rail. The load carrying capacities of the lower part of the diagonals have been increased by larger connection plates, in steel S460. To see the consequence the loss of one pair of diagonals, the FEM-model was

modified. It has been proven that the load carrying capacity of the structure will be big enough to avoid any catastrophic consequences, even if one pair of diagonals is totally damaged.

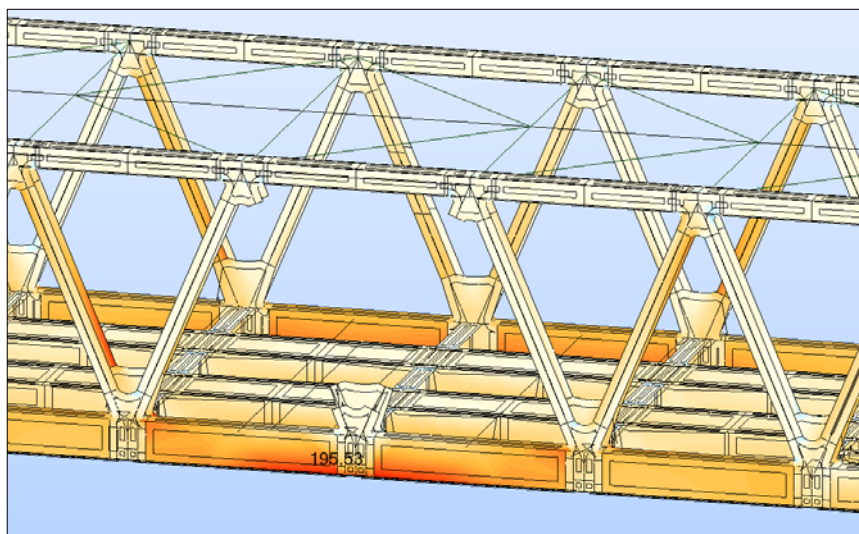

Figure 11: One of the accidental load cases that has been studied.

#### 3.4.4 *Fabrication and installation*

Promecon, a MT Højgaard subsidiary with long experience from bridge projects, was awarded the contract for fabrication, delivery and installation of the lifting bridge section and the lifting machinery.

The fabrication and the assembly of the lift bridge and the appertaining machinery for are carried out in the Far East, in yard with an adjacent deep water port. The separate parts are produced in a workshop 10 km from the assembly yard. Before transportation from workshop to the assembly yard a full NDT check is being carried out and the sections are painted so only the final layer of paint will be applied in the yard after final fitting and welding.



Figure 12. Assembly of the lifting bridge section in a deep water port.

One challenge was translating the requirements of “BRO 2004”, “BV BRO 7” and “BSK 99” into understandable terms in general and into equivalent Eurocodes for a country that normally works with American and Japanese codes. However, the basic requirements are the same no matter whatever standard you comply with.

A quality plan made in accordance with the required standards for all fabrication was implemented and during the fabrication a full time inspection team from Denmark performed supervision. Local NDT supervisors and paint supervisors performed the day to day check, and the final control check was carried out by supervisors from Denmark. Banverket (the client) has also contracted a 3rd party independent supervisor who visits the fabrication site several times for control checks.

The main bridge structure will be transported to a site using a conventional heavy lift vessel, which will bring the bridge structure to Södertälje port as deck cargo. Upon arrival it will be lifted unto a barge and then sailed in between the pylons to be in position to be lifted up to the parking brackets in the top of the pylons. Installation of the bridge structure will be done using wirestrand lifting devices placed on top of each of the four pylons.

For the permanent lifting operation of the bridge the pylons are furnished with four lift winches complete with individual counterweights with a lifting capacity of 110 tons. The design is similar to conventional lift machinery. All structures have been made in the Far East apart from the main gear and drives. Above all, the challenge is the very installation due to the difficult access to the construction site. A conventional mobile crane has limited access and the tower cranes have a limited lifting capacity. To allow the lifting-in of counterweights a crane was developed and placed on the tower tops in order to mount the up to 14 ton wire sheaves on the pylon top. To illustrate the process we have attached a 3D illustration showing how the lifting machinery is fitted into and on top of the pylons. See figure 13.

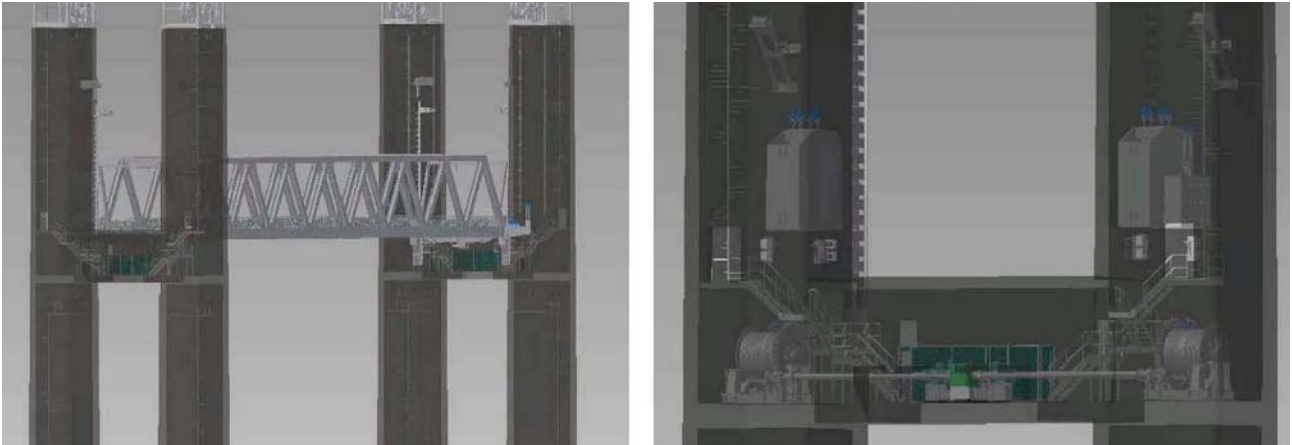

Figure 13. The lifting system